

PULSAFEEDER®

Liquid Level Wands were designed to indicate when there is a low level condition in the chemical tank and to turn off a metering pump to prevent the pump from running dry.

The level wand is designed to be inserted into a chemical container with a 2" bung hole. The wand can then be adjusted to the proper level and secured in place. A low voltage cable connects the control box to the level wand.

Level Wands are independent level sensors to supply a dry contact switch closure to any device requiring a low level contact, such as the PULSAtron electronic metering pumps or any controller with a dry contact drum level input.

Features

- Low Level Indicators
- Adjustable Level Wand



Liquid Level Wand

Specifications and Model Selection

Liquid Level Wands	
Part Number	Description
16-171-81-4	Level Wand - Level adjustable up to 60". Switch contacts 28 VDC 50 mA. Order 16-171-81-3 when using PULSAtron Pumps with the Stop Function Feature.
16-171-81-1	Level Wand - Level adjustable up to 42". Switch contacts 28 VDC 50 mA. Order 16-171-81-3 when using PULSAtron Pumps with the Stop Function Feature.
16-171-81-2	Level Wand - Level adjustable up to 26". Switch contacts 28 VDC 50 mA. Order 16-171-81-3 when using PULSAtron Pumps with the Stop Function Feature.
16-171-81-3	10' cable w/ connector for 16-171-81-1, 16-171-81-2 & 16-171-81-4 to use w/ PULSAtron Pumps with the Stop Function Feature

NOTE: When utilizing a Pump Model w/ external/stop feature, order 16-171-81-4, 16-171-81-1 or 16-171-81-2 in addition to 16-171-81-3.

Engineering Data

16-171-81-4 Wand:	64" x 3/4" (162.56 x 1.9 cm)
16-171-81-1 Wand:	46" x 3/4" (116.8 x 1.9 cm)
16-171-81-2 Wand:	30" x 3/4" (76.2 x 1.9 cm)
Wand Material:	PVC and Polypropylene

Typical Installation

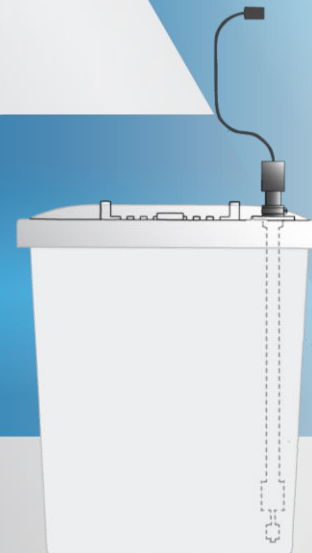

novatech
INTERNATIONAL

sales@novatech-usa.com
www.novatech-usa.com

Tel: (866) 433-6682 Fax: (866) 433-6684
Tel: (281) 359-8538 Fax: (281) 359-0084

PULSAFEEDER
27101 Airport Road
Punta Gorda, FL 33982
Phone: +1(941) 575-3800
Fax: +1(941) 575-4085

www.pulsatron.com



An ISO 9001 Certified Company

LLW001 K15

IDEX
FLUID & METERING